

BBB™

PVC-U PIPES & FITTINGS



CONTENTS

COMPANY INTRODUCTION	P3
OUR PRODUCT	P4
SPECIFICATIONS & STANDARDS	P5
PVC-U PRESSURE PIPES WITH SOLVENT CEMENT JOINT	P6-P7
PVC-U PRESSURE FITTINGS	P8-P13
PVC-U JAPANESE INDUSTRIAL STANDARD PIPES	P14
PVC-U JAPANESE INDUSTRIAL STANDARD FITTINGS	P15-P16
PVC-U PRESSURE PIPES WITH RUBBER-RING JOINT	P17
PVC-U SOIL, WASTE AND VENTILATING (S.W.V) PIPES	P18
PVC-U SOIL, WASTE AND VENTILATING (S.W.V) FITTINGS	P19-P25
PVC-U UNDERGROUND DRAINAGE AND SEWERAGE PIPES	P26
PVC-U UNDERGROUND DRAINAGE AND SEWERAGE FITTINGS	P27-P28
QUALITY ASSURANCE	P29
PIPE INSTALLATION WITH SOLVENT CEMENT JOINTS	P30
PIPE INSTALLATION WITH RUBBER-RING JOINTS	P31



COMPANY INTRODUCTION

Founded in 1973, Bina Plastic has grown significantly into a company employing several hundred staffs and possesses ten large and modern factories. Bina Plastic supplies complete piping systems comprising various kind of plastics including PVC-U, PPR, HDPE and ABS. Bina Plastic piping systems are used in a broad cross-section of markets such as water supply, wastewater and stormwater drainage, irrigation, electrical and telecommunication.



QUALITY DRIVEN
since 1973

 **BINA PLASTIC**
INDUSTRIES SDN BHD

QUALITY DRIVEN since 1973

GENERAL

Polyvinyl Chloride, commonly abbreviated PVC, is a widely used thermoplastic. Unplasticized PVC (PVC-U) is rigid type of PVC means without the use of plasticizing agents. PVC has long been considered to be one of the most durable polymer for both underground and aboveground piping systems and is commonly used for a variety of pressure and gravity applications including potable water distribution, irrigation systems and sewer industries. Its light weight, high strength and low reactivity makes it particularly well-suited to these purposes

Material Characteristics



LIGHT WEIGHT

PVC-U's light weight makes it easier and less costly to handle, transport and install. In fact, most PVC-U pipe and fitting sizes can be handled manually, reducing the need for expensive installation equipment.



HIGHER FLOW RATE

PVC-U pipes provide smooth wall surface to give high flow rate and reduce the possibility of build up inside the system which will lead to blockages.



CHEMICAL RESISTANCE

PVC-U pipes and fittings have outstanding chemical resistance to acids, alkalis, oxidising and reducing agent and make them exceptionally suitable for wide range of industrial and housing applications. Generally, PVC-U is resistant to most oils, fats, alcohols and aromatic free gasoline, but is unsuitable for use with aromatic and chlorinated hydrocarbons, ketones, esters and cyclic ethers.



CORROSION RESISTANCE

PVC-U pipes and fittings are non-conductors of electricity and immune to electrochemical reactions caused by acids, alkalis and salts that cause corrosion in metals.



FLAME RESISTANCE

PVC-U material do not support combustion and will self-extinguish when ignited.



IMPACT STRENGTH

Under normal conditions, PVC-U pipes possess relatively high resistance to impact damage when compared to pipes made from clay, concrete and most other conventional materials.



FAVOURABLE COST

PVC-U pipes and fittings are competitive with other materials, particularly when installation and life cycle operating costs are taken into consideration.

SPECIFICATIONS & STANDARDS

PIPES

PVC-U PRESSURE PIPES WITH SOLVENT CEMENT JOINT	NORMINAL SIZE (mm)	SPECIFICATION
PN 9 (CLASS C)	80,100,155,200 & 250	MS 628-2:2014
PN 12 (CLASS D)	32,40,50,65,80,100,155,200,250 & 300	MS 628-2:2014
PN 15 (CLASS E)	15,20,25,32,40,50,65,80,100,155,200,250 & 300	MS 628-2:2014
CLASS B	80,100,155,200 & 250	BS 3506:1969
CLASS 7	15,20,25,32,40 & 50	BS 3506:1969
JIS (CLASS AE)	150, 200, 250, 300, 350, 400 & 450	JIS K6741
JIS (CLASS AEO)	150, 200, 250, 300, 350 & 400	JIS K6741

PVC-U PRESSURE PIPES WITH RUBBER-RING JOINT	NORMINAL SIZE (mm)	SPECIFICATION
BELL-MOUTH PN 12 (CLASS D)	80,100,155,200,250 & 300	MS 628-2:2014
BELL-MOUTH PN 15 (CLASS E)	80,100,155,200,250 & 300	MS 628-2:2014

PVC-U SOIL WASTE & VENTILATING	NORMINAL SIZE (mm)	SPECIFICATION
SWV AREA CODE B & BD	36,43,56,82,110,160,200,250 & 315	MS 1063:2002 BS EN 1329-1:2000

PVC-U UNDERGROUND DRAINAGE & SEWERAGE	NORMINAL SIZE (mm)	SPECIFICATION
UNDERGROUND AREA CODE D	100,155,200,250 & 315	MS 979:PART 1 & 2:1985 MS 1063:2002(D)

FITTINGS

PRODUCT TYPE	NORMINAL SIZE (mm)	SPECIFICATION
PVC-U PRESSURE FITTINGS	15,20,25,32,40,50,65,80,100,155 & 200	MS 628:PART 2:1999
JIS FITTINGS	150, 200, 250 & 300	JIS K6741
PVC-U SWV FITTINGS	36,43,56,82,110,160,200,250 & 315	MS 1063:2002 BS EN 1329-1:2000
PVC-U UNDERGROUND FITTINGS	100,155 & 200	MS 979:PART 1:1985

PVC-U PRESSURE PIPES WITH SOLVENT CEMENT JOINT

These pipes are complied with **MS 628** and **BS 3506**, which are intended to be used for pressure application in cold water services.

The pressure rating of the pipes are as following:

- PN 9 (CLASS C)
- PN 12 (CLASS D)
- PN 15 (CLASS E)
- CLASS B (PN 6)
- CLASS 7



PN 9 (CLASS C)

PRODUCT CODE	NOMINAL SIZE		OUTSIDE DIAMETER (mm)		WALL THICKNESS (mm)		LENGTH (meter)
	In.	mm	Min	Max	Min	Max	
PP/C-080-6S	3	80	88.7	89.1	3.5	4.1	5.8
PP/C-100-6S	4	100	114.1	114.5	4.5	5.2	5.8
PP/C-155-6S	6	155	168.0	168.5	6.6	7.6	5.8
PP/C-200-6S	8	200	218.8	219.4	7.8	9.0	5.8
PP/C-250-6S	10	250	272.6	273.4	9.7	11.2	5.8

PN 12 (CLASS D)

PRODUCT CODE	NOMINAL SIZE		OUTSIDE DIAMETER (mm)		WALL THICKNESS (mm)		LENGTH (meter)
	In.	mm	Min	Max	Min	Max	
PP/D-032-6S	1¼	32	42.1	42.4	2.2	2.7	5.8
PP/D-040-6S	1½	40	48.1	48.4	2.5	3.0	5.8
PP/D-050-6S	2	50	60.2	60.5	3.1	3.7	5.8
PP/D-065-6S	2½	65	75.0	75.3	3.9	4.5	5.8
PP/D-080-6S	3	80	88.7	89.1	4.6	5.3	5.8
PP/D-100-6S	4	100	114.1	114.5	6.0	6.9	5.8
PP/D-155-6S	6	155	168.0	168.5	8.8	10.2	5.8
PP/D-200-6S	8	200	218.8	219.4	10.3	11.9	5.8
PP/D-250-6S	10	250	272.6	273.4	12.8	14.8	5.8
PP/D-300-6S	12	300	323.4	324.3	15.2	17.7	5.8

PN 15 (CLASS E)

PRODUCT CODE	NOMINAL SIZE		OUTSIDE DIAMETER (mm)		WALL THICKNESS (mm)		LENGTH (meter)
	In.	mm	Min	Max	Min	Max	
PP/E-015-6S	½	15	21.2	21.5	1.7	2.1	5.8
PP/E-020-6S	¾	20	26.6	26.9	1.9	2.5	5.8
PP/E-025-6S	1	25	33.4	33.7	2.2	2.7	5.8
PP/E-032-6S	1¼	32	42.1	42.4	2.7	3.2	5.8
PP/E-040-6S	1½	40	48.1	48.4	3.1	3.7	5.8
PP/E-050-6S	2	50	60.2	60.5	3.9	4.5	5.8
PP/E-065-6S	2½	65	75.0	75.3	4.8	5.5	5.8
PP/E-080-6S	3	80	88.7	89.1	5.7	6.6	5.8
PP/E-100-6S	4	100	114.1	114.5	7.3	8.4	5.8
PP/E-155-6S	6	155	168.0	168.5	10.8	12.5	5.8
PP/E-200-6S	8	200	218.8	219.4	12.6	14.5	5.8
PP/E-250-6S	10	250	272.6	273.4	15.7	18.1	5.8
P5/E-300-6S	12	300	323.4	324.3	18.7	21.6	5.8

CLASS B (PN 6)

PRODUCT CODE	NOMINAL SIZE		OUTSIDE DIAMETER (mm)		WALL THICKNESS (mm)		LENGTH (meter)
	In.	mm	Min	Max	Min	Max	
PP/B-080-6S	3	80	88.7	89.1	2.9	3.4	5.8
PP/B-100-6S	4	100	114.1	114.5	3.4	4.0	5.8
PP/B-155-6S	6	155	168.0	168.5	4.5	5.2	5.8
PP/B-200-6S	8	200	218.8	219.4	5.3	6.1	5.8
PP/B-250-6S	10	250	272.6	273.4	6.6	7.6	5.8

CLASS 7

PRODUCT CODE	NOMINAL SIZE		OUTSIDE DIAMETER (mm)		WALL THICKNESS (mm)		PRESSURE RATING (Bar)	LENGTH (meter)
	In.	mm	Min	Max	Min	Max		
PP/7-015-6S	1/2	15	21.2	21.5	3.7	4.3	40	5.8
PP/7-020-6S	3/4	20	26.6	26.9	3.9	4.5	32	5.8
PP/7-025-6S	1	25	33.4	33.7	4.5	5.2	32	5.8
PP/7-032-6S	1 1/4	32	42.1	42.4	4.8	5.5	28	5.8
PP/7-040-6S	1 1/2	40	48.1	48.4	5.1	5.9	25	5.8
PP/7-050-6S	2	50	60.2	60.5	5.5	6.3	22	5.8

**Remark : 15mm -100mm Plain End, 155mm and above Socket End*



PVC-U PRESSURE PIPES WITH SOLVENT CEMENT JOINT

PVC-U PRESSURE FITTINGS

THREADED FEMALE ELBOW 90°

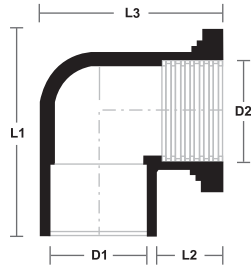

Dimension (mm)

Code No	Size (mm)	D1	D2	L1	L2	L3
FP/TFE-015-1/2	15-(1/2)	21.5	19.3	56.8	12.9	41.5
FP/TFE-020-1/2	20-(1/2)	26.8	19.3	59.0	14.9	49.2

THREADED FEMALE TEE

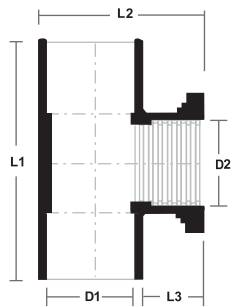

Dimension (mm)

Code No	Size (mm)	D1	D2	L1	L2	L3
FP/TFE-015-1/2	15-(1/2)	21.4	19.4	84.3	45.7	17.3
FP/TFE-020-1/2	20-(1/2)	26.9	19.7	81.9	48.1	13.1

THREADED FEMALE COUPLING

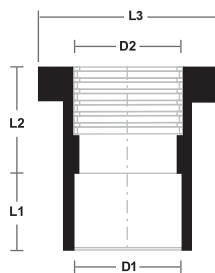

Dimension (mm)

Code No	Size (mm)	D1	D2	L1	L2	L3
FP/TFC-015-1/2	15-(1/2)	21.8	19.3	32.2	15.5	34.2
FP/TFC-020-1/2	20-(1/2)	26.8	19.3	28.8	20.6	37.6

PVC-U PRESSURE FITTINGS

ELBOW 45°

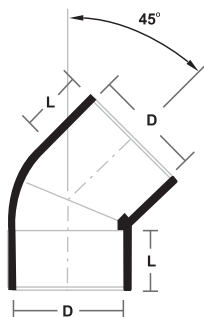

Dimension (mm)

Code No	Size (mm)	D	L
FP/E45-015T	15	21.6	25.5
FP/E45-020T	20	26.8	28.1
FP/E45-025T	25	33.6	28.3
FP/E45-032T	32	42.3	32.1
FP/E45-040T	40	48.2	22.0
FP/E45-050T	50	60.3	26.0
FP/E45-065T	65	75.1	51.0
FP/E45-080T	80	88.8	39.5
FP/E45-100T	100	114.5	50.5
FP/E45-155BS	155	168.5	82.2

EQUAL ELBOW

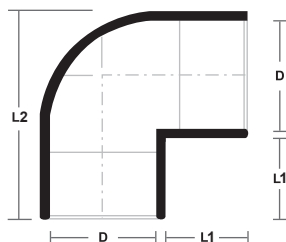

Dimension (mm)

Code No	Size (mm)	D	L1	L2
FP/EE-015T	15	21.3	26.8	51.0
FP/EE-020T	20	26.7	29.5	57.0
FP/EE-025T	25	33.5	27.2	67.2
FP/EE-032T	32	42.2	32.1	81.5
FP/EE-040T	40	48.2	38.0	94.4
FP/EE-050T	50	60.3	44.0	117.0
FP/EE-065T	65	75.1	56.6	146.0
FP/EE-080T	80	88.8	79.9	174.5
FP/EE-100T	100	114.2	95.4	228.6
FP/EE-155BS	155	168.3	129.1	321.9
FP/EE-200BS	200	218.8	105.4	331.0

REDUCING ELBOW

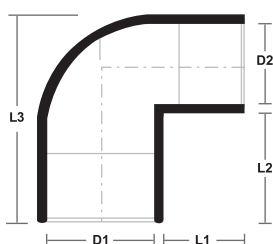

Dimension (mm)

Code No	Size (mm)	D1	D2	L1	L2	L3
FP/RE-020-15	20x15	26.7	21.3	22.0	22.0	52.9
FP/RE-025-15	25x15	33.5	21.3	28.0	28.1	60.4
FP/RE-025-20	25x20	33.5	26.7	28.0	28.2	54.6

P/T ELBOW (FAUCET)

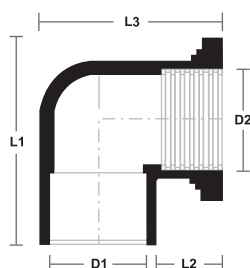

Dimension (mm)

Code No	Size (mm)	D1	D2	L1	L2	L3
FP/PTE-015	15	21.3	22.0	57.9	16.9	48.2
FP/PTE-020	20	26.7	26.8	59.5	24.5	56.6
FP/PTE-025	25	33.5	33.5	68.7	26.5	69.4
FP/PTE-032	32	42.2	42.8	75.0	24.3	76.8
FP/PTE-040	40	48.2	48.4	95.1	27.2	86.1
FP/PTE-050	50	60.3	60.2	106.4	33.0	102.3

PVC-U PRESSURE FITTINGS

EQUAL TEE

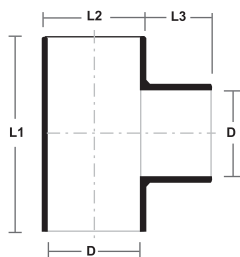

Dimension (mm)

Code No	Size (mm)	D	L1	L2	L3
FP/ET-015T	15	21.3	76.1	26.2	25.1
FP/ET-020T	20	26.7	84.7	33.6	26.3
FP/ET-025T	25	33.5	102.6	40.5	26.8
FP/ET-032T	32	42.2	114.6	50.3	27.1
FP/ET-040T	40	48.2	121.6	56.5	34.1
FP/ET-050T	50	60.3	145.8	67.3	42.4
FP/ET-065T	65	75.1	196.7	85.1	44.4
FP/ET-080T	80	88.8	224.8	97.4	44.7
FP/ET-100T	100	114.2	240.7	122.3	77.4
FP/ET-155T	155	168.3	351.3	176.5	77.6

REDUCING TEE

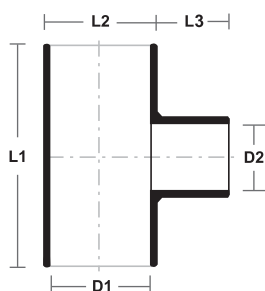

Dimension (mm)

Code No	Size (mm)	D1	D2	L1	L2	L3
FP/RT-020-15	20x15	26.7	21.3	84.8	32.4	28.7
FP/RT-025-15	25x15	33.5	21.3	102.5	40.2	27.2
FP/RT-025-20	25x20	33.5	26.7	102.5	40.2	27.2
FP/RT-032-15	32x15	42.2	21.3	114.4	50.2	28.1
FP/RT-032-20	32x20	42.2	26.7	114.4	50.2	28.1
FP/RT-032-25	32x25	42.2	33.5	114.4	50.2	28.1
FP/RT-040-15	40x15	48.2	21.3	121.5	56.5	34.1
FP/RT-040-20	40x20	48.2	26.7	121.5	56.5	34.1
FP/RT-040-25	40x25	48.2	33.5	121.5	56.5	34.1
FP/RT-040-32	40x32	48.2	42.2	121.5	56.5	34.1
FP/RT-050-15	50x15	60.3	21.3	145.4	69.4	42.3
FP/RT-050-20	50x20	60.3	26.7	145.4	69.4	42.3
FP/RT-050-25	50x25	60.3	33.5	145.4	69.4	42.3
FP/RT-050-32	50x32	60.3	42.2	145.4	69.4	42.3
FP/RT-050-40	50x40	60.3	48.2	145.4	69.4	42.3
FP/RT-065-40T	65x40	75.1	48.2	196.5	84.5	59.2
FP/RT-065-50T	65x50	75.1	60.3	196.5	84.5	60.8
FP/RT-080-25T	80x25	88.8	33.5	224.4	101.5	66.0
FP/RT-080-32T	80x32	88.8	42.2	224.4	101.5	66.0
FP/RT-080-50T	80x50	88.8	60.3	224.4	101.5	66.0
FP/RT-100-50T	100x50	114.2	60.3	248.6	129.3	71.9
FP/RT-100-80T	100x80	114.2	88.8	248.6	129.3	71.9
FP/RT-155-100BS	155x100	168.3	114.2	225.9	101.8	66.1

P/T TEE (FAUCET)

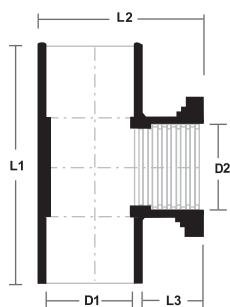

Dimension (mm)

Code No	Size (mm)	D1	D2	L1	L2	L3
FP/PTT-015	15	21.3	22.0	66.0	40.1	16.9

PVC-U PRESSURE FITTINGS

DOUBLE END (DE) SOCKET

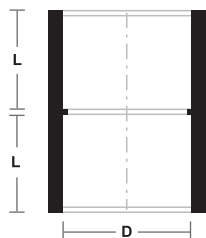

Dimension (mm)			
Code No	Size (mm)	D	L
FP/DES-015T	15	21.3	21.1
FP/DES-020T	20	26.7	22.3
FP/DES-025T	25	33.5	22.7
FP/DES-032T	32	42.2	43.0
FP/DES-040T	40	48.2	42.8
FP/DES-050T	50	60.3	53.4
FP/DES-065T	65	75.1	67.8
FP/DES-080T	80	88.8	78.5
FP/DES-100T	100	114.2	99.4
FP/DES-155BS	155	168.3	149.7
FP/DES-200BS	200	218.8	146.5

REDUCING SOCKET

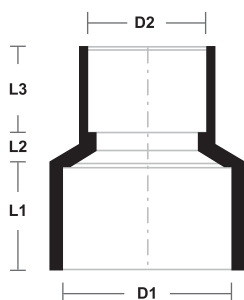

Dimension (mm)						
Code No	Size (mm)	D1	D2	L1	L2	L3
FP/RS-020-15	20x15	26.7	21.3	21.2	11.9	17.3
FP/RS-025-15	25x15	33.5	21.3	24.3	10.5	19.9
FP/RS-025-20	25x20	33.5	26.7	24.5	11.9	21.9
FP/RS-032-15	32x15	42.2	21.3	27.2	17.2	25.7
FP/RS-032-20	32x20	42.2	26.7	27.2	17.2	25.9
FP/RS-032-25	32x25	42.2	33.5	28.0	16.3	25.9
FP/RS-040-15	40x15	48.2	21.3	28.7	16.5	28.0
FP/RS-040-20	40x20	48.2	26.7	28.7	16.3	28.0
FP/RS-040-25	40x25	48.2	33.5	28.6	16.6	28.0
FP/RS-040-32	40x32	48.2	42.2	28.6	16.7	28.1
FP/RS-050-15	50x15	60.3	21.3	35.5	16.7	33.4
FP/RS-050-20	50x20	60.3	26.7	35.6	16.6	33.3
FP/RS-050-25	50x25	60.3	33.5	34.4	15.1	36.1
FP/RS-050-32	50x32	60.3	42.2	38.1	15.2	33.3
FP/RS-050-40	50x40	60.3	48.2	35.5	16.2	33.1
FP/RS-065-50T	65x50	75.1	60.3	64.4	14.7	59.6
FP/RS-080-50T	80x50	88.8	60.3	66.5	33.6	63.6
FP/RS-100-50T	100x50	114.2	60.3	99.4	19.1	70.4
FP/RS-100-80T	100x80	114.2	88.8	98.9	20.9	68.9
FP/RS-155-100BS	155x100	168.3	114.2	119.3	38.8	96.9

P/T SOCKET (FAUCET)

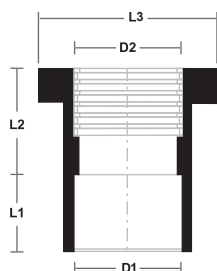

Dimension (mm)						
Code No	Size (mm)	D1	D2	L1	L2	L3
FP/PTS-015	15	21.3	22.0	24.2	24.2	30.2
FP/PTS-020	20	26.7	26.8	24.4	32.0	34.2
FP/PTS-025	25	33.5	33.5	28.1	37.2	43.5
FP/PTS-032	32	42.2	42.8	41.9	26.5	52.7
FP/PTS-040	40	48.2	48.4	45.1	33.8	59.6
FP/PTS-050	50	60.3	60.2	60.0	37.7	71.8
FP/PTS-065	65	75.1	74.9	69.0	38.0	86.6
FP/PTS-080	80	88.8	84.3	73.8	44.3	105.8
FP/PTS-100	100	114.2	110.0	89.9	57.9	114.1

PVC-U PRESSURE FITTINGS

VALVE SOCKET

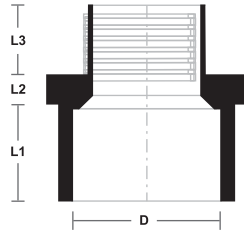

Dimension (mm)

Code No	Size (mm)	D	L1	L2	L3
FP/VS-015	15	21.3	26.3	7.8	17.5
FP/VS-020	20	26.7	29.9	7.6	20.1
FP/VS-025	25	33.5	31.1	8.2	23.8
FP/VS-032	32	42.2	36.3	8.9	24.3
FP/VS-040	40	48.2	42.6	10.2	26.3
FP/VS-050	50	60.3	67.8	11.5	30.6
FP/VS-065	65	75.1	64.5	14.7	34.6
FP/VS-080	80	88.8	66.8	16.2	40.2
FP/VS-100	100	114.2	102.1	24.8	54.6

V-TANK CONNECTOR

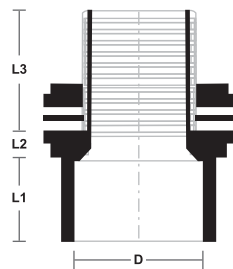

Dimension (mm)

Code No	Size (mm)	D	L1	L2	L3
FP/TC-015V	15	21.3	32.6	11.0	32.7
FP/TC-020V	20	26.7	33.6	11.0	37.8
FP/TC-025V	25	33.5	42.4	10.6	40.1
FP/TC-032V	32	42.2	51.5	11.6	57.9
FP/TC-040V	40	48.2	62.8	13.3	56.9
FP/TC-050V	50	60.3	64.5	14.7	34.6

REDUCING BUSH

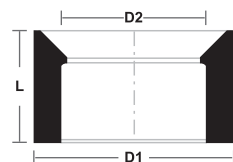

Dimension (mm)

Code No	Size (mm)	D1	D2	L
FP/RB-020-15	20X15	26.7	21.3	21.2
FP/RB-025-15	25X15	33.5	21.3	26.4
FP/RB-025-20	25X20	33.5	26.7	26.8
FP/RB-032-15	32X15	42.2	21.3	31.7
FP/RB-032-20	32X20	42.2	26.7	31.7
FP/RB-032-25	32X25	42.2	33.5	31.7
FP/RB-040-15	40X15	48.2	21.3	34.1
FP/RB-040-20	40X20	48.2	26.7	34.1
FP/RB-040-25	40X25	48.2	33.5	34.1
FP/RB-040-32	40X32	48.2	42.2	34.1
FP/RB-050-15	50X15	60.3	21.3	37.4
FP/RB-050-20	50X20	60.3	26.7	37.4
FP/RB-050-25	50X25	60.3	33.5	37.4
FP/RB-050-32	50X32	60.3	42.2	37.4
FP/RB-050-40	50X40	60.3	48.2	37.6
FP/RB-080-50	80X50	82.1	60.8	47.8
FP/RB-100-50	100X50	114.2	60.9	42.7
FP/RB-100-80	100X80	114.2	88.8	42.7

PVC-U PRESSURE FITTINGS

PLUG

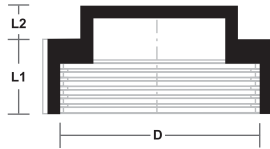
Dimension (mm)

Code No	Size (mm)	D	L1	L2
FP/PL-015	15	21.3	12.4	11.5
FP/PL-020	20	26.7	16.1	10.0
FP/PL-025	25	33.5	17.7	14.6
FP/PL-032	32	42.2	26.7	17.6
FP/PL-040	40	48.2	26.8	17.0
FP/PL-050	50	60.3	27.2	17.0

END CAP

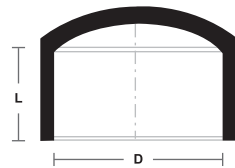
Dimension (mm)

Code No	Size (mm)	D	L
FP/EC-015	15	21.3	18.8
FP/EC-020	20	26.7	21.8
FP/EC-025	25	33.5	24.2
FP/EC-032	32	42.2	31.6
FP/EC-040	40	48.2	31.7
FP/EC-050	50	60.3	32.0
FP/EC-065	65	75.1	64.6
FP/EC-080	80	88.8	67.4
FP/EC-100	100	114.2	96.0
FP/EC-155	155	168.3	145.2

FLANGE

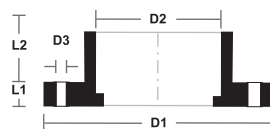
Dimension (mm)

Code No	Size (mm)	D1	D2	D3	L1	L2
FP/FLG-025	25	75.7	33.5	15.3	14.2	31.3
FP/FLG-040	40	86.2	48.5	18.3	16.2	43.5
FP/FLG-050	50	153.4	60.3	20.6	17.1	56.1
FP/FLG-065	65	174.7	76.2	22.2	18.8	60.5
FP/FLG-080	80	184.0	90.1	20.7	21.1	64.7
FP/FLG-100	100	203.7	114.6	21.5	21.7	72.5
FP/FLG-155BS	150	220.2	168.3	23.8	24.4	120.9
FP/FLG-200BS	200	264.9	218.8	20.3	24.6	164.0

PVC-U JAPANESE INDUSTRIAL STANDARD (JIS) PIPES

CLASS AE (TYPE VU)

NOMINAL SIZE (mm)	OUTSIDE DIAMETER (mm)	TOLERANCE OF OUTSIDE DIAMETER (mm)	WALL THICKNESS (mm)
150	165.0	±0.5	5.1
200	216.0	±0.7	6.5
250	267.0	±0.9	7.8
300	318.0	±1.0	9.2
350	370.0	±1.2	10.5
400	420.0	±1.3	10.8
450	470.0	±1.5	13.2

CLASS AEO

NOMINAL SIZE (mm)	OUTSIDE DIAMETER (mm)	TOLERANCE OF OUTSIDE DIAMETER (mm)	WALL THICKNESS (mm)
150	165.0	±0.5	3.1
200	216.0	±0.7	4.5
250	267.0	±0.9	5.3
300	318.0	±1.0	7.0
350	370.0	±1.2	9.5
400	420.0	±1.3	10.3

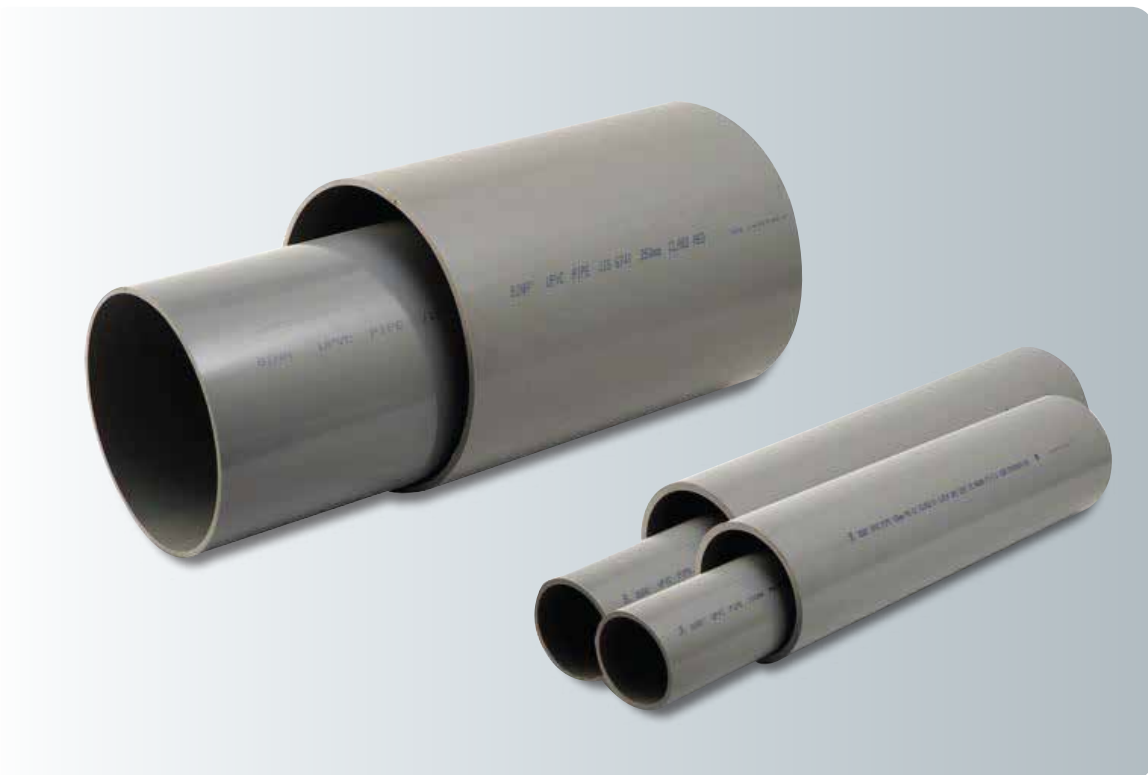

PVC-U PRESSURE PIPES WITH SOLVENT CEMENT JOINT (JIS K6741 Standard)

PVC-U JAPANESE INDUSTRIAL STANDARD (JIS) FITTINGS

DOUBLE END (DE) SOCKET (AE)

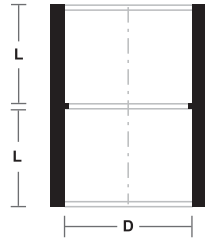

Dimension (mm)				
Code No	Size (mm)	D	L	L1
FP/DES-150W	150	165.4	110.8	228.5
FP/DES-200W	200	216.5	150.3	300.6
FP/DES-250W	250	268.6	140.0	286.9
FP/DES-300W	300	318.0	163.9	336.0

REDUCING SOCKET (AE)

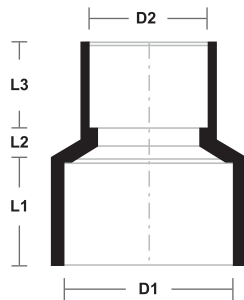

Dimension (mm)						
Code No	Size (mm)	D1	D2	L1	L2	L3
FP/RS-150-100W	150 X 100	165.4	115.3	60.3	35.0	59.9

END CAP (AW)

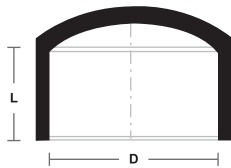

Dimension (mm)			
Code No	Size (mm)	D	L
FP/EC-150	150	165.4	161.4

FLANGE (AW)

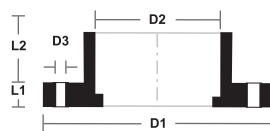

Dimension (mm)						
Code No	Size (mm)	D1	D2	D3	L1	L2
FP/FLG-150	150	283.2	165.4	24.2	24.0	121.5
FP/FLG-200	200	324.0	216.5	19.4	25.3	165.2

PVC-U JAPANESE INDUSTRIAL STANDARD (JIS) FITTINGS

ELBOW 45° (AE)

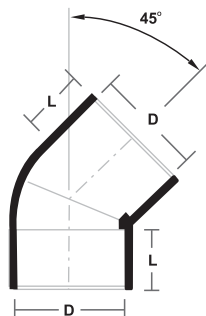

Dimension (mm)			
Code No	Size (mm)	D	L
FP/E45-150	150	165.4	87.3
FP/E45-200	200	216.5	109.7
FP/E45-250	250	268.6	137.1
FP/E45-300	300	318.0	151.8

EQUAL ELBOW (AE)

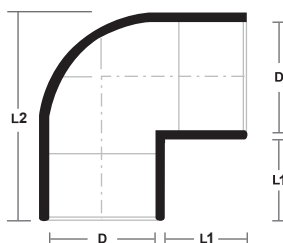

Dimension (mm)				
Code No	Size (mm)	D	L1	L2
FP/EE-150W	150	165.4	82.5	258.2
FP/EE-200W	200	216.5	105.5	330.4
FP/EE-250W	250	268.6	124.2	400.0
FP/EE-300W	300	318.0	146.0	485.0

EQUAL TEE (AE)

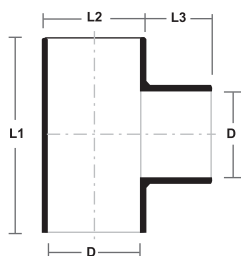

Dimension (mm)					
Code No	Size (mm)	D	L1	L2	L3
FP/ET-150W	150	165.4	331.0	175.9	77.5
FP/ET-200W	200	216.5	442.0	232.9	104.9

REDUCING TEE (AE)

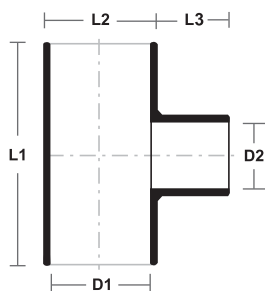

Dimension (mm)						
Code No	Size (mm)	D1	D2	L1	L2	L3
FP/RT-150-100W	150 X 100	165.4	114.9	331.0	175.6	77.7
FP/RT-200-100W	200X100	216.5	114.9	440.3	232.9	92.0
FP/RT-200-155W	200X155	216.5	165.9	440.3	232.9	90.8

PVC-U PRESSURE PIPES WITH RUBBER-RING JOINT



SPECIFICATIONS OF PRESSURE PIPES

Colour	Grey or Blue
Length	6m
Type of Joint	Rubber - Ring Joint

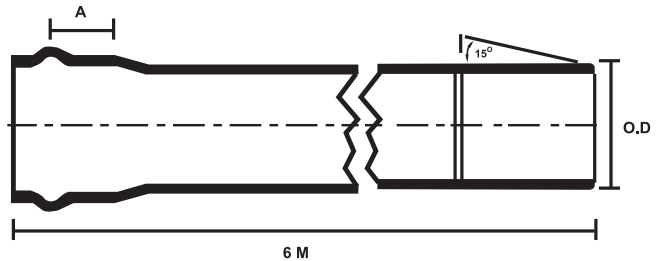

PN 12 (CLASS D)

PRODUCT CODE	NOMINAL SIZE		OUTSIDE DIAMETER (mm)		WALL THICKNESS (mm)		INSERTION LENGTH (A) (mm)
	In.	mm	Min	Max	Min	Max	
PBU5/D-080BM-6S	3	80	88.7	89.1	4.6	5.3	85.5
PBU5/D-100BM-6S	4	100	114.1	114.5	6.0	6.9	86.2
PBU5/D-155BM-6S	6	155	168.0	168.5	8.8	10.2	91.9
PBU5/D-200BM-6S	8	200	218.8	219.4	10.3	11.9	115.1
PBU5/D-250BM-6S	10	250	272.6	273.4	12.8	14.8	128.6
PBU5/D-300BM-6S	12	300	323.4	324.3	15.2	17.7	136.0

PN 15 (CLASS E)

PRODUCT CODE	NOMINAL SIZE		OUTSIDE DIAMETER (mm)		WALL THICKNESS (mm)		INSERTION LENGTH (A) (mm)
	In.	mm	Min	Max	Min	Max	
PBU5/E-080BM-6S	3	80	88.7	89.1	5.7	6.6	85.5
PBU5/E-100BM-6S	4	100	114.1	114.5	7.3	8.4	86.2
PBU5/E-155BM-6S	6	155	168.0	168.5	10.8	12.5	91.9
PBU5/E-200BM-6S	8	200	218.8	219.4	12.6	14.5	115.1
PBU5/E-250BM-6S	10	250	272.6	273.4	15.7	18.1	128.6
PBU5/E-300BM-6S	12	300	323.4	324.3	18.7	21.6	136.0



PVC-U SOIL, WASTE AND VENTILATING (S.W.V) PIPES

These pipes are complied with **MS 1063** which are intended to be used for soil and waste discharge pipe work for conveyance of domestic waste water (low and high temperature), ventilating pipe work within building structure.

This standard is equivalent to **BS 5255, BS 4514, BS EN 1401 and BS EN 1329.**



SPECIFICATIONS OF SOIL, WASTE AND VENTILATING (S.W.V) PIPES

Colour	White
Length	4m or 5.8m
Type of Joint	Solvent Cement Weld Joint

PRODUCT CODE	NOMINAL SIZE		OUTSIDE DIAMETER (mm)		WALL THICKNESS (mm)			
					Application Area			
					B		BD	
In.	mm	Min	Max	Min	Max	Min	Max	
PU/036-6S	1 1/4	36	36.2	36.5	3.0	3.5	-	-
PU/043-6S	1 1/2	43	42.8	43.1	3.0	3.5	-	-
PU/056-6S	2	56	55.8	56.1	3.0	3.5	-	-
PU/082-6S	3	82	82.4	82.8	3.0	3.5	3.0	3.5
PU/110-6S	4	110	110.0	110.3	3.2	3.8	3.2	3.8
PU/160-6S	6	160	160.0	160.4	3.2	3.8	4.0	4.6
PU/200-6S	8	200	200.0	200.5	3.9	4.5	4.9	5.6
PU/250-6S	10	250	250.0	250.5	4.9	5.6	6.2	7.1
PU/315-6S	12	315	315.0	315.6	6.2	7.1	7.7	8.7

Application area code:

Code "B" = Application for components intended for use above ground inside the buildings, or for components outside buildings fixed onto the wall.
 Code "BD" = Application for components intended for above ground use for both inside the buildings, or components outside buildings fixed onto the wall and buried in building structures.



PVC-U SOIL, WASTE AND VENTILATING (S.W.V) FITTINGS

45° PLAIN BEND

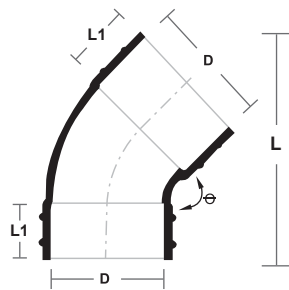

SWEEP BEND

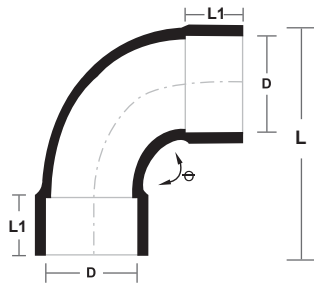

SWEEP BEND WITH I/O

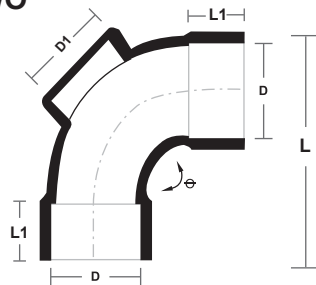

WC CONNECTING BEND (PLAIN)

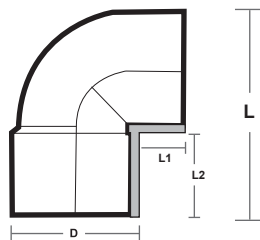

WC CONNECTING BEND WITH I/O

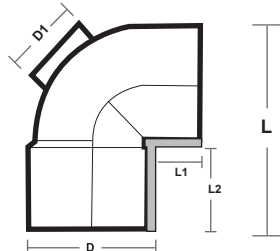

Dimension (mm)

Code No	Size (mm)	Angle (°)	D	L	L1
FU/135BP-032S	36	45	36.3	72.8	24.0
FU/135BP-040S	43	45	42.9	83.4	25.0
FU/135BP-050S	56	45	55.9	96.6	28.0
FU/135BP-082S	82	45	82.6	142.8	45.0
FU/135BP-110S	110	45	110.2	182.4	50.0
FU/135BP-160S	160	45	160.4	272.6	78.0
FU/135BP-200S	200	45	200.5	340.4	100.0
FU/135BP-250S	250	45	250.5	368.0	83.2
FU/135BP-315S	315	45	315.5	400.6	102.2

Dimension (mm)

Code No	Size (mm)	Angle (°)	D	L	L1
FU/SB-032S	36	92	36.3	85.2	24.0
FU/SB-040S	43	92	42.9	92.1	25.0
FU/SB-050S	56	92	55.9	99.1	28.0
FU/SB-082S	82	92	82.6	172.7	45.0
FU/SB-110S	110	92	110.2	192.7	50.0
FU/SB-160S	160	92	160.4	200.5	78.0
FU/SB-200S	200	92	200.5	340.4	99.0
FU/SB-250S	250	92	250.5	372.0	83.0
FU/SB-315S	315	92	315.5	469.1	102.0

Dimension (mm)

Code No	Size (mm)	Angle (°)	D	D1	L	L1
FU/SB-040S-I	43	92	42.9	38.5	80.9	25.0
FU/SB-050S-I	56	92	55.9	44.3	99.1	28.0
FU/SB-082S-I	82	92	82.6	55.6	142.8	45.0
FU/SB-110S-I	110	92	110.2	85.4	172.7	50.0
FU/SB-160S-I	160	92	160.4	110.6	272.6	78.0
FU/SB-200S-I	200	92	200.5	110.5	340.4	99.0

Dimension (mm)

Code No	Size (mm)	Angle (°)	D	L	L1	L2
FU/WCCB-110S	110	90	110.4	147.5	33.0	49.5

Dimension (mm)

Code No	Size (mm)	Angle (°)	D	D1	L	L1	L12
FU/WCCB-110S-I	110	90	110.4	55.6	147.5	33.0	49.5

PVC-U SOIL, WASTE AND VENTILATING (S.W.V) FITTINGS

EQUAL SINGLE BRANCH

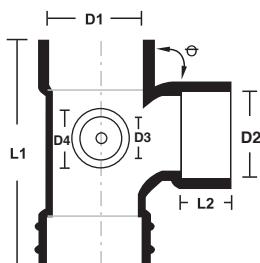

Dimension (mm)

Code No	Size (mm)	Angle (°)	D1	D2	D3	D4	L1	L2
FU/ESB-032S	36	92	36.3	36.3	-	-	89.0	24.0
FU/ESB-040S	43	92	42.9	42.9	-	-	109.0	25.0
FU/ESB-050S	56	92	55.9	55.9	-	-	135.0	28.0
FU/ESB-082S	82	92	82.6	82.6	-	-	205.0	45.0
FU/ESB-082-50S	82x56	92	82.6	56.0	-	-	173.4	30.2
FU/ESB-110S	110	92	110.2	110.2	56.0	-	270.0	50.0
FU/ESB-110-50S	110x56	92	110.2	56.0	56.0	-	270.0	29.9
FU/ESB-110-82S	110x82	92	110.2	82.6	56.0	-	270.0	47.8
FU/ESB-160S	160	92	160.4	160.2	56.0	-	315.0	75.3
FU/ESB-160-110S	160x110	92	160.4	110.2	56.0	-	376.0	52.0
FU/ESB-200S	200	92	200.2	200.2	56.0	82.0	395.2	83.6
FU/ESB-200-110S	200x110	92	200.3	110.2	82.1	56.4	380.0	53.6
FU/ESB-200-160S	200x160	92	200.3	160.3	82.4	55.5	380.0	75.3
FU/ESB-250-250S	250	92	250.1	250.2	-	-	410.0	82.6
FU/ESB-250-110S	250x110	92	250.3	110.6	-	-	366.0	55.3
FU/ESB-250-160S	250x160	92	250.3	160.3	-	-	366.0	58.4
FU/ESB-250-200S	250x200	92	250.4	200.2	-	-	366.0	81.4
FU/ESB-315-315S	315	92	315.7	315.9	-	-	529.7	91.0
FU/ESB-315-110S	315x110	92	315.9	110.6	-	-	376.0	55.2
FU/ESB-315-160S	315x160	92	315.9	160.8	-	-	376.0	58.1
FU/ESB-315-200S	315x200	92	315.9	200.2	-	-	476.0	81.9
FU/ESB-315-250S	315x250	92	315.9	250.2	-	-	476.0	81.5

EQUAL SINGLE BRANCH WITH I/O

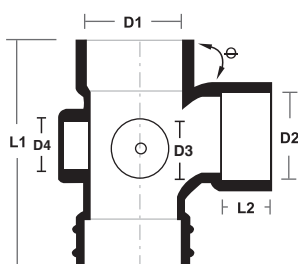

Dimension (mm)

Code No	Size (mm)	Angle (°)	D1	D2	D3	D4	L1	L2
FU/ESB-050S-I	56	92	55.9	55.9	-	44.3	135.0	28.0
FU/ESB-082S-I	82	92	82.9	82.6	-	44.4	205.0	45.0
FU/ESB-082-50I	82x56	92	82.6	56.0	-	44.4	173.4	30.2
FU/ESB-110S-I	110	92	110.2	110.2	56.0	85.2	250.0	50.0
FU/ESB-110-50I	110x56	92	110.2	56.0	56.0	85.2	270.0	29.9
FU/ESB-110-82I	110x82	92	110.2	82.6	56.0	85.2	270.0	47.8
FU/ESB-160S-I	160	92	160.4	160.4	56.0	110.3	315.0	75.3
FU/ESB-160-110I	160x110	92	160.4	110.2	56.0	110.3	376.0	52.0

45° Y-BRANCH (Y-TEE)

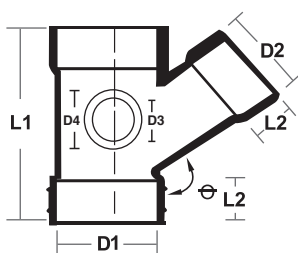

Dimension (mm)

Code No	Size (mm)	Angle (°)	D1	D2	D3	D4	L1	L2
FU/YT-040S	43	45	42.9	42.9	-	-	110.0	25.0
FU/YT-050S	56	45	55.9	55.9	-	-	135.0	28.0
FU/YT-082S	82	45	82.6	82.6	-	-	205.0	46.5
FU/YT-110S	110	45	110.2	110.2	-	-	255.0	50.0
FU/YT-160S	160	45	160.4	160.4	56.0	82.0	315.0	73.5
FU/YT-160-110S	160x110	45	160.4	110.2	56.0	82.0	376.0	52.1
FU/YT-200S	200	45	200.4	200.4	-	-	428.0	62.0

PVC-U SOIL, WASTE AND VENTILATING (S.W.V) FITTINGS

45° Y-BRANCH (Y-TEE) WITH I/O

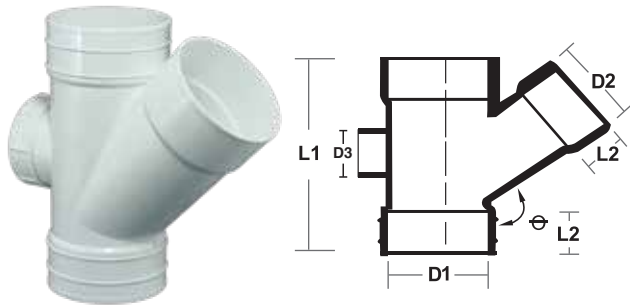

Dimension (mm)

Code No	Size (mm)	Angle (°)	D1	D2	D3	L1	L2
FU/YT-110S-I	110	45	110.2	110.6	84.7	267.1	52.0

EQUAL DOUBLE BRANCH (CROSS TEE)

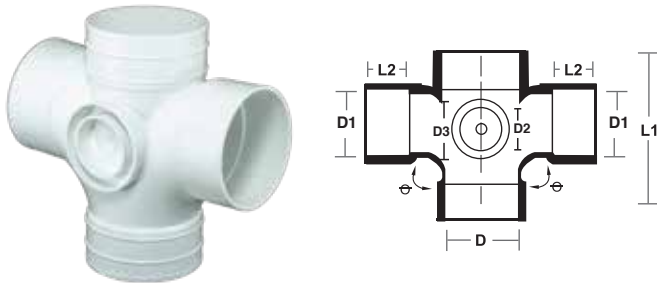

Dimension (mm)

Code No	Size (mm)	Angle (°)	D	D1	D2	D3	L1	L2
FU/CT-110-110S	110x110	92	110.2	110.6	56.0	82.0	270.0	50.0
FU/CT-160-110S	160x110	92	160.4	110.2	56.0	82.0	315.3	50.0

STRAIGHT COUPLING

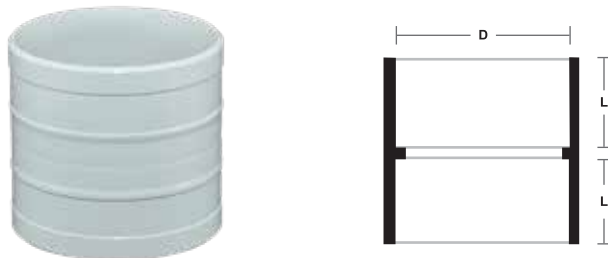

Dimension (mm)

Code No	Size (mm)	D	L
FU/SC-032S	36	36.3	24.0
FU/SC-040S	43	42.9	25.0
FU/SC-050S	56	55.9	28.0
FU/SC-082S	82	82.6	45.0
FU/SC-110S	110	110.2	50.0
FU/SC-160S	160	160.4	78.0
FU/SC-200S	200	200.4	122.5
FU/SC-250S	250	250.4	83.2
FU/SC-315S	315	315.5	102.2

PIPE SLEEVE

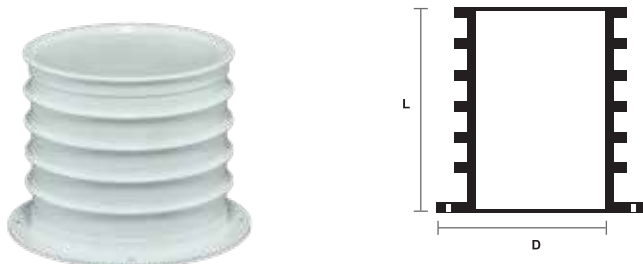

Dimension (mm)

Code No	Size (mm)	D	L
FU/PS-036S	36	36.5	110.8
FU/PS-043S	43	43.3	109.2
FU/PS-050S	56	56.2	110.2
FU/PS-082S	82	82.7	109.8
FU/PS-110S	110	110.3	109.6
FU/PS-160S	160	160.8	165.9
FU/EU-160K	160	160.7	110.3
FU/PS-200S	200	200.4	122.5

PVC-U SOIL, WASTE AND VENTILATING (S.W.V) FITTINGS

P-TRAP

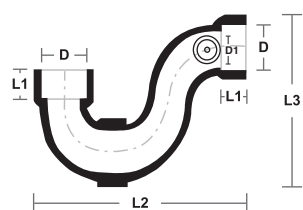
Dimension (mm)

Code No	Size (mm)	D	D1	L1	L2	L3
FU/PT-110S	110	110.2	56.0	50.0	380.0	270.0

P-TRAP WITH I/O

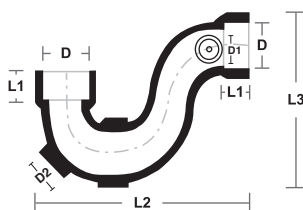
Dimension (mm)

Code No	Size (mm)	D	D1	D2	L1	L2	L3
FU/PT-050S-I	50	55.9	-	38.4	50.0	240.0	180.0
FU/PT-110S-I	110	110.2	56.0	56.2	50.0	380.0	270.0

S-TRAP WITH I/O

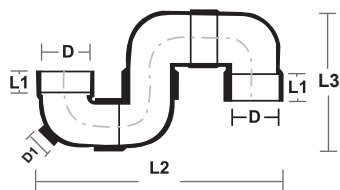
Dimension (mm)

Code No	Size (mm)	D	D1	L1	L2	L3
FU/ST-110S-I	110	110.2	48.6	50.0	470.0	285.0

FLOOR GULLY WITH I/O

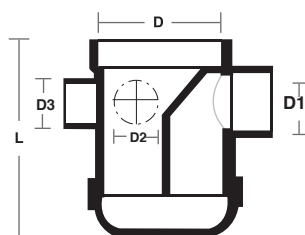
Dimension (mm)

Code No	Size (mm)	D	D1	D2	D3	L
FU/FG-110-50S	110x56x43x56	110.2	56.0	43.0	56.0	198.0
FU/FG-110-82S	110x82x43x56	110.2	82.6	43.0	56.0	198.0
FU/FG-110-5-5S	110x56x56x56	110.2	56.0	56.0	56.0	198.0

PVC-U SOIL, WASTE AND VENTILATING (S.W.V) FITTINGS

FLOOR GULLY (TOP ACCESS)

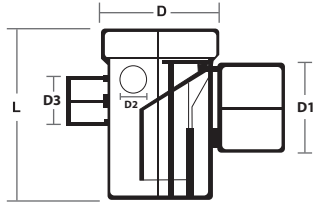

Dimension (mm)						
Code No	Size (mm)	D	D1	D2	D3	L
FU/FG-110-8-5S	110x82x56x56	110.2	82.9	56.0	56.0	164.0

BOSS CONNECTOR

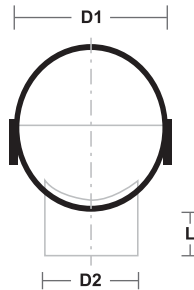

Dimension (mm)				
Code No	Size (mm)	D1	D2	L
FU/BC-082-50S	82x56	82.6	56.0	28.0
FU/BC-110-50S	110x56	110.2	56.0	28.0
FU/BC-110-82S	110x82	110.2	82.6	45.0
FU/BC-160-82S	160x82	160.4	82.6	45.0
FU/BC-160-110S	160x110	160.4	110.2	50.0

BUSH REDUCER

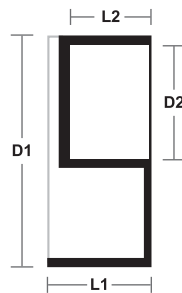

Dimension (mm)					
Code No	Size (mm)	D1	D2	L1	L2
FU/SR-040-32S	43x36	42.9	36.3	22.0	19.0
FU/SR-050-32S	56x36	55.9	26.3	28.0	19.0
FU/SR-050-40S	56x43	55.9	42.0	28.0	22.0
FU/SR-082-50S	82x56	82.6	56.0	45.0	28.0
FU/SR-110-50S	110x56	110.2	56.0	50.0	28.0
FU/SR-110-82S	110x82	110.2	82.6	50.0	45.0
FU/SR-160-82S	160x82	160.4	82.6	78.0	45.0
FU/SR-160-110S	160x110	160.4	110.2	78.0	50.0
FU/SR-200-110S	200x110	200.4	110.2	80.0	48.0
FU/SR-200-160S	200x160	200.4	160.4	80.0	58.0
FU/SR-250-110S	250x110	250.2	110.2	80.7	80.7
FU/SR-250-160S	250x160	250.2	160.5	80.7	80.7
FU/SR-250-200S	250x200	250.2	200.7	80.7	80.7
FU/SR-315-110S	315x110	315.7	110.2	84.1	48.5
FU/SR-315-160S	315x160	315.7	160.6	90.4	90.4
FU/SR-315-200S	315x200	315.7	250.8	90.4	90.4
FU/SR-315-250S	315x250	315.7	250.8	90.4	90.4

PVC-U SOIL, WASTE AND VENTILATING (S.W.V) FITTINGS

LEVEL INVERT REDUCER

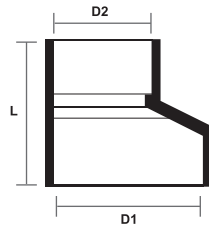

Dimension (mm)				
Code No	Size (mm)	D1	D2	L
FU/RS-082-50S	82x56	82.6	56.0	124.5
FU/RS-110-50S	110x56	110.2	56.0	124.6
FU/RS-110-82S	110x82	110.2	82.6	124.5
FU/RS-200-110S	200x110	200.4	110.2	160.0
FU/RS-200-160S	200x160	200.4	160.2	160.0

CONCENTRIC REDUCER

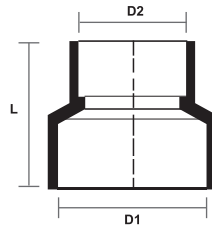

Dimension (mm)				
Code No	Size (mm)	D1	D2	L
FU/RS-160-110S	160x110	160.4	110.2	141.3

END CAP

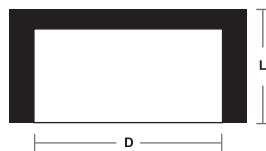

Dimension (mm)			
Code No	Size (mm)	D	L
FU/EC-050S	56	55.9	35.0
FU/EC-082S	82	82.6	45.3
FU/EC-110S	110	110.2	25.0
FU/EC-160S	160	160.4	75.8
FU/EU-200S	200	200.6	100.4

VENT COWL

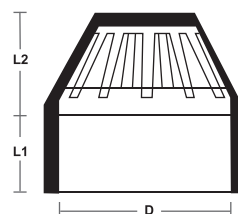

Dimension (mm)				
Code No	Size (mm)	D	L1	L2
FU/VC-050S	56	55.9	29.8	43.2
FU/VC-082S	82	82.6	25.0	48.0
FU/VC-110S	110	110.2	26.0	64.0
FU/VC-160S	160	160.4	51.9	90.1

PVC-U SOIL, WASTE AND VENTILATING (S.W.V) FITTINGS

ACCESS PLUG WITH CAP

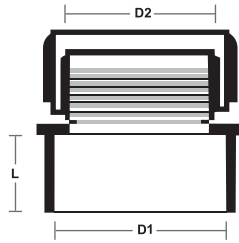

Dimension (mm)				
Code No	Size (mm)	D1	D2	L
FU/AP-040S	43	42.9	44.3	42.7
FU/AP-050S	56	55.9	45.4	44.3
FU/AP-082S	82	82.6	87.0	51.5
FU/AP-110S	110	110.2	76.5	84.3
FU/AP-160S	160	160.4	159.0	95.0

P/T SOCKET (FAUCET)

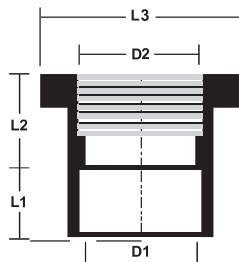

Dimension (mm)						
Code No	Size (mm)	D1	D2	L1	L2	L3
FU/PTS-032S	36	36.3	42.2	27.5	34.8	52.8
FU/PTS-040S	43	42.9	48.2	31.7	39.2	59.5

P/T ELBOW (FAUCET)

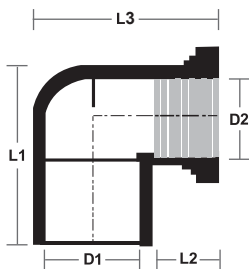

Dimension (mm)						
Code No	Size (mm)	D1	D2	L1	L2	L3
FU/PTE-032S	36	36.3	42.2	72.8	24.4	69.4
FU/PTE-040S	43	42.9	48.2	79.5	27.6	85.0

U-BODY

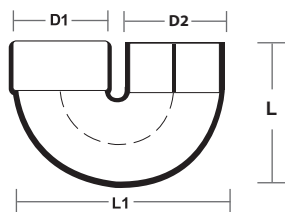

Dimension (mm)					
Code No	Size (mm)	D1	D2	L	L1
FU/UB-110S	110	110.4	110.4	165.5	248.0

U-BODY WITH I/O

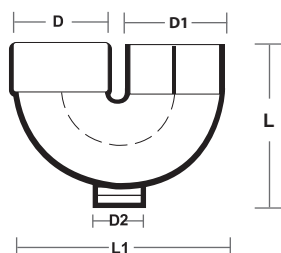

Dimension (mm)						
Code No	Size (mm)	D	D1	D2	L	L1
FU/UB-110S-I	110	110.4	110.4	40.1	188.2	248.0

PVC-U UNDERGROUND DRAINAGE AND SEWERAGE PIPES

These pipes are complied with **MS 979** and **MS 1063**, which intended to be used for soil and waste discharge systems buried in ground within the building structure. These standards are equivalent to **BS 4660**, **BS 5481** and **BS EN 1329**.

SPECIFICATIONS OF UNDERGROUND DRAINAGE AND SEWERAGE PIPES

Colour	Brown
Length	5.8m
Type of Joint	Solvent Cement Weld Joint



PRODUCT CODE	NOMINAL SIZE		OUTSIDE DIAMETER (mm)		WALL THICKNESS (mm)	
	In.	mm	Min	Max	Min	Max
P5/UG-110-6S	4	100	110.0	110.4	3.2	-
P5/UG-155-6S	6	155	160.0	160.6	4.1	-
P5/UG-200-6S	8	200	200.0	200.5	4.9	5.6
P5/UG-250-6S	10	250	250.0	250.5	6.2	7.1
P5/UG-315-6S	12	315	315.0	315.6	7.7	8.7



PVC-U UNDERGROUND DRAINAGE AND SEWERAGE FITTINGS

45° PLAIN BEND

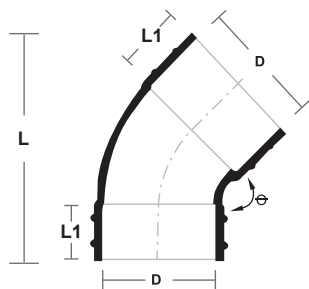

Dimension (mm)					
Code No	Size (mm)	Angle (°)	D	L	L1
FUG/135BP-110S	100	45	110.2	182.4	50.0
FUG/135BP-160S	155	45	160.4	272.6	78.0
FUG/135BP-200S	200	45	200.2	340.4	100.0

SWEEP BEND

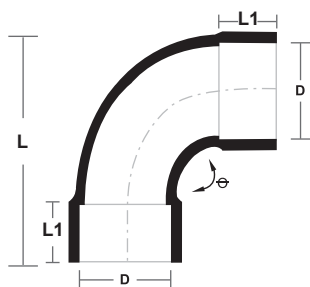

Dimension (mm)					
Code No	Size (mm)	Angle (°)	D	L	L1
FUG/SB-110S	100	92.5	100.4	192.7	52.0
FUG/SB-160S	155	92.5	160.4	200.5	79.8
FUG/SB-200S	200	92.5	200.2	340.4	99.3

EQUAL SINGLE BRANCH

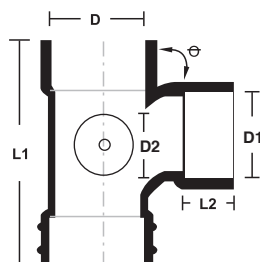

Dimension (mm)							
Code No	Size (mm)	Angle (°)	D	D1	D2	L1	L2
FUG/ESB-110S	100	92.5	110.2	110.2	56.0	250.0	50.0
FUG/ESB-160S	155	92.5	160.4	160.4	56.0	370.0	77.0
FUG/ESB-160-110S	155x100	92.5	160.4	110.2	56.0	315.0	52.0

PVC-U UNDERGROUND DRAINAGE AND SEWERAGE FITTINGS

STRAIGHT COUPLING

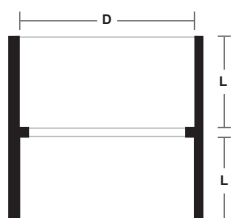

Dimension (mm)			
Code No	Size (mm)	D	L
FUG/SC-110S	100	110.2	50.0
FUG/SC-160S	155	160.4	78.0
FUG/SC-200S	200	200.4	122.5

P - TRAP

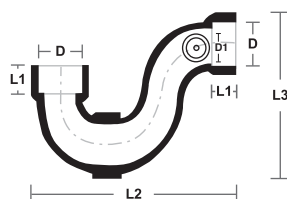

Dimension (mm)						
Code No	Size (mm)	D	D1	L1	L2	L3
FUG/PT-110S	100	110.2	56.0	50.0	380.0	270.0

U - BODY

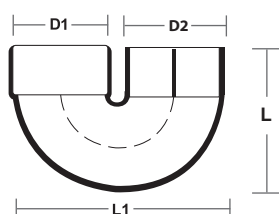

Dimension (mm)					
Code No	Size (mm)	D1	D2	L	L1
FUG/UB-110S	100	110.2	110.4	165.5	248.0

QUALITY ASSURANCE

We committed to supply the best quality products to our customers. All production processes from the start to end are strictly monitored and recorded. Well trained staffs are exercising inspection and quality control using calibrated equipments. Our factory had been equipped with all necessary testing equipments.



Appearance, dimensions and ovality inspection

All tests are carried out in our laboratory and the results have been properly recorded. We assure that only products which pass our stringent testing in compliance with the relevant standard's requirements will only be sold to the market.



**Hydrostatic
Pressure Test**



Impact Test



Heat Reversion Test



Acetone Test



Tensile Test

PIPE INSTALLATION WITH SOLVENT CEMENT JOINTS



1 Joint Preparation

Cut pipe square with the axis, using a fine-tooth saw with a miter box or guide. Remove all burrs and break the sharp lead edges.



2 Cleaning

Surfaces to be joined must be cleaned and free of dirt, moisture, oil, and other foreign material.



3 Application of Solvent Cement

PVC solvent cement is fast drying and should be applied as quickly as possible, consistent with good workmanship. Follow the manufacturer's recommendations for application of solvent cement.



4 Joint Assembly

While both the inside socket surface and the outside surface of the spigot of the pipe are WET with solvent cement, forcefully bottom the spigot in the socket. Turn the pipe or fitting 1/4 turn during assembly (but not after the pipe is bottomed) to distribute the cement evenly. Assembly should be completed within 30 seconds after the last application of solvent cement.



5 After Assembly

Wipe excess cement from the pipe at the end of the socket. Any gaps in the cement bead around the pipe perimeter may indicate a defective assembly. Handle the newly assembled joints carefully after 1 hour.

Important Points of Pipe Installation with Solvent Cement Joints

1. The joining surfaces must be clean and dry.
2. Sufficient cement must be applied to fill the gap between male and female ends.
3. The assembly must be made while the surfaces are still wet and fluid.
4. Completed joints should not be disturbed until they have cured sufficiently to withstand handling.
5. Keep the solvent cement closed and shaded when not actually in use. Discard the solvent cement when a noticeable change in viscosity occurs, when the cement does not flow freely from the brush, or when the cement appears lumpy and stringy.

PIPE INSTALLATION WITH RUBBER - RING JOINTS



1 Cleaning

Clean the socket area. Remove sand, dirt, grease and debris.



2 Insert Rubber Ring

Insert the rubber ring into the ring groove.



3 Application of Lubricant

(a) Clean the spigot end of the pipe as far back as the reference line.

(b) Apply lubricant to the spigot end and approximately mid-way back to the reference line.



4 Joint Assembly

Insert the spigot end into the socket until it contacts the rubber ring uniformly. Apply steady pressure by hand or by mechanical means until the spigot slips through the rubber ring. Insert pipe until the reference line is just visible at the face of each socket.

Important Points of Pipe Installation with Rubber - Ring Joints

1. The rubber ring is correctly fitted when the thickness cross section of the ring is positioned towards the outside of the socket and groove in the rubber ring is positioned inside the socket.
2. Check the rubber ring to make sure it is sealed uniformly in the ring groove by running your finger around the inner edge of the rubber ring.
3. Keep lubricant areas clean. If dirt or sand adheres to lubricated areas, clean and re-lubricate.
4. Bar and block assembly is recommended because a worker is able to feel the amount of force being used and whether the joint goes together smoothly.
5. If undue resistance to pipe insertion is encountered, disassemble the joint and check the position of the rubber ring.
 - If the rubber ring has been dislocated from the ring groove, inspect the pipe and rubber ring for damage, replace damaged items, clean components and repeat the installation steps.
 - If the rubber ring is still properly positioned, verify proper positioning of the reference line. Relocated the line if it is not correctly positioned.
 - If the pipe still cannot be inserted properly, please do contact us for assistance.

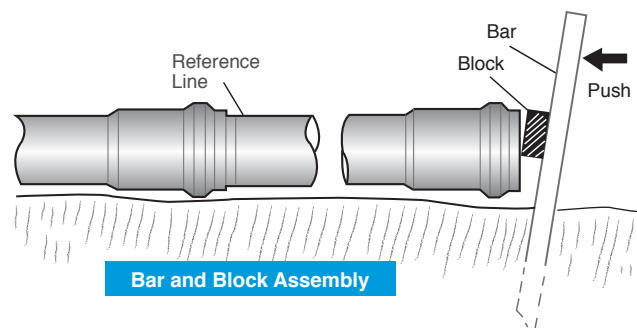



QUALITY DRIVEN since 1973

HEAD OFFICE / FACTORY 1

Address : Lot 4844, Jalan KPB 11A,
Balakong New Village Industrial Estate, 43300
Seri Kembangan, Selangor Darul Ehsan,
Malaysia.

Tel : +603 - 7800 0355
Fax : +603 - 8961 2313 (Sales) / 1348 (Acc)
Email : info@binaplast.com
Website : www.binaplast.com

FACTORY 2

Address : Lot 2079, Jalan KPB 12,
Balakong New Village Industrial Estate, 43300
Seri Kembangan, Selangor Darul Ehsan,
Malaysia

Tel : +603 - 8964 2084

FACTORY 6

Address : Lot 4151, Jalan KB 2/15, Kampung Baru Balakong,
43300 Seri Kembangan, Selangor Darul Ehsan,
Malaysia

Tel : +603 - 8964 5924

NILAI FACTORY

Address : Lot 158, Jalan Permata 1,
Arab Malaysian Industrial Park ,
71800 Nilai, Negeri Sembilan.
Malaysia

Tel : +606 - 799 9909



www.binaplast.com

Disclaimer:

Bina Plastic Industries Sdn Bhd reserves the right to modify the details in this publication as products and specifications are updated and improved.
The content of this publication is for general information only and it is the user's responsibility to determine the suitability of any product for the purpose intended.
The document does not contain technical information.